

8 7 6 5 4 3 2 1

PROPRIETARY NOTICE:  
 TECHNICAL DATA AND DESIGNS DISCLOSED HEREIN ARE THE  
 EXCLUSIVE PROPERTY OF AMERICAN AIR ARMS AND / OR CONTAIN  
 PROPRIETARY RIGHTS OF OTHERS AND ARE NOT TO BE USED FOR  
 MANUFACTURE OR OTHER PURPOSE WITHOUT PRIOR WRITTEN  
 AUTHORITY OF AMERICAN AIR ARMS.

REVISION HISTORY			
REV	DESCRIPTION	DATE	APPROVED
A	INITIAL RELEASE	01/04/2018	TC

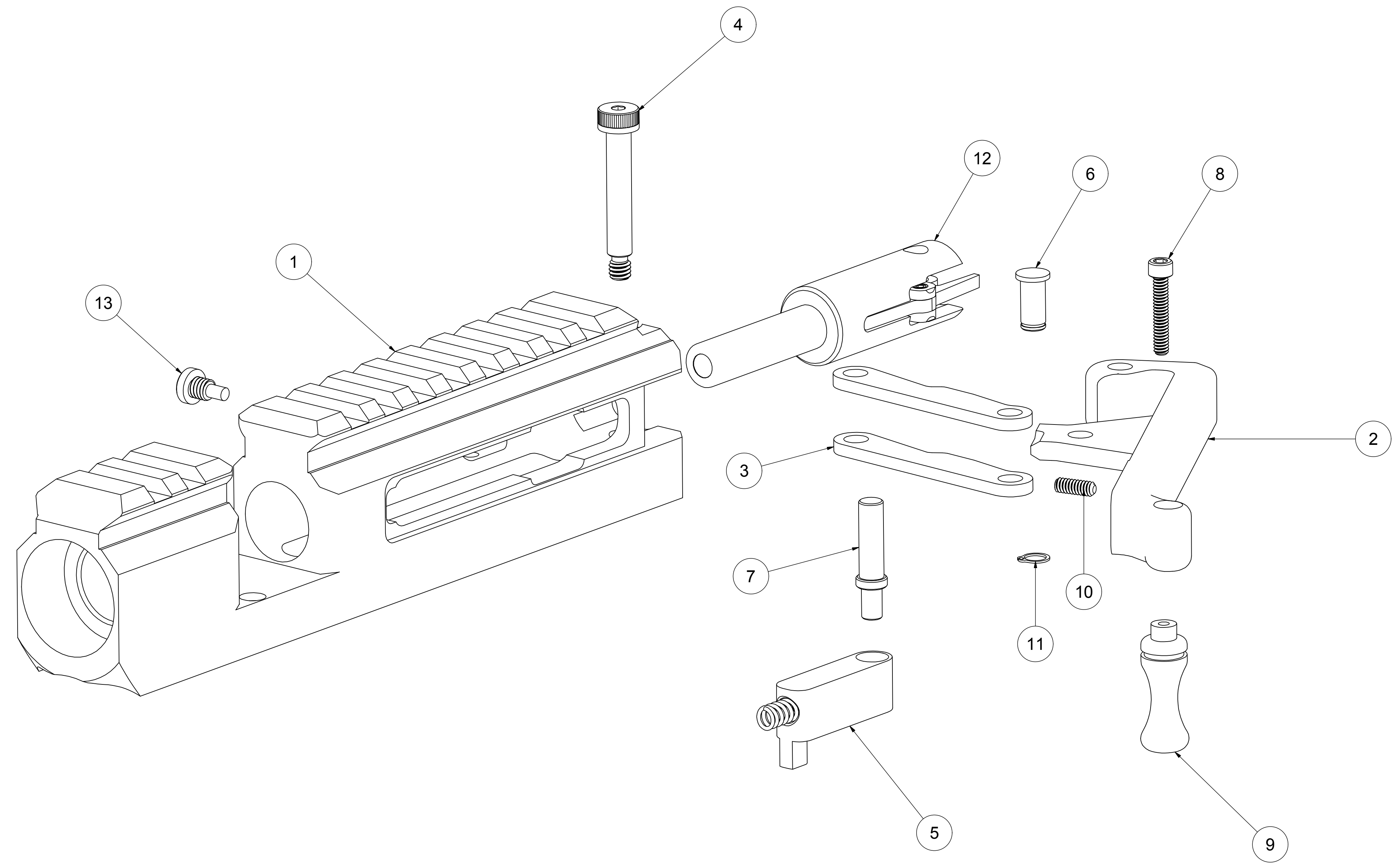

Parts List, E-100-0002-01, receiver, upper, 357 LH			
ITEM	QTY	PART NUMBER	DESCRIPTION
1	1	D-100-0002-01	receiver, 357, LH
2	1	D-100-0013-00	lever - 308, 357
3	2	D-100-0016-00	link, lever
4	1	C-270-0188-16	shoulder bolt, .187X1.
5	1	D-100-0010-00	bolt traveler
6	1	D-100-0017-00	pin, lever link
7	1	D-100-0018-00	pin, bolt/traveler
8	1	C-200-0440-10	Cap screw, 4-40X.58
9	1	D-100-0014-00	knob, lever
10	1	C-210-0440-05	set screw, 4-40x.32
11	1	C-030-0020-00	retaing ring, .187
12	1	E-100-0011-01	bolt, 357
13	1	D-100-0011-01	screw, bolt probe reset

UNLESS OTHERWISE SPECIFIED:  
 ALL DIMENSIONS ARE IN INCHES  
 TOLERANCES ARE:  
 FRACTIONS ANGLES DECIMALS  
 +/- .1/32" +/- .5 .XX=.01  
 .XXX=.005  
 SURFACE FINISH 63 ✓

APPROVALS	DATE
DRAWN Tom	1/3/2018
ELEC.	
MECH.	
PROD.	
QA	
CONFIG.	

**American Air Arms**  
 (661) 468-7520 www.americanairarms.com

TITLE  
**Receiver, Upper Assembly, 357 LH**

SIZE <b>B</b>	PROJECT	REF: P/N <b>E-100-0002-01</b>	REV A
SCALE NONE	FILE TYPE / NAME INVENTOR: E-100-0002-01.idw	SHEET 1	OF 2

Parts List, E-100-0011-01, bolt - 357			
ITEM	QTY	PART NUMBER	DESCRIPTION
1	1	D-100-0012-00	probe pin assy.
2	1	D-100-0019-01	bolt, 357
3	1	E-100-0013-00	probe catch assy.
4	1	C-035-0005-01	spring, probe shaft

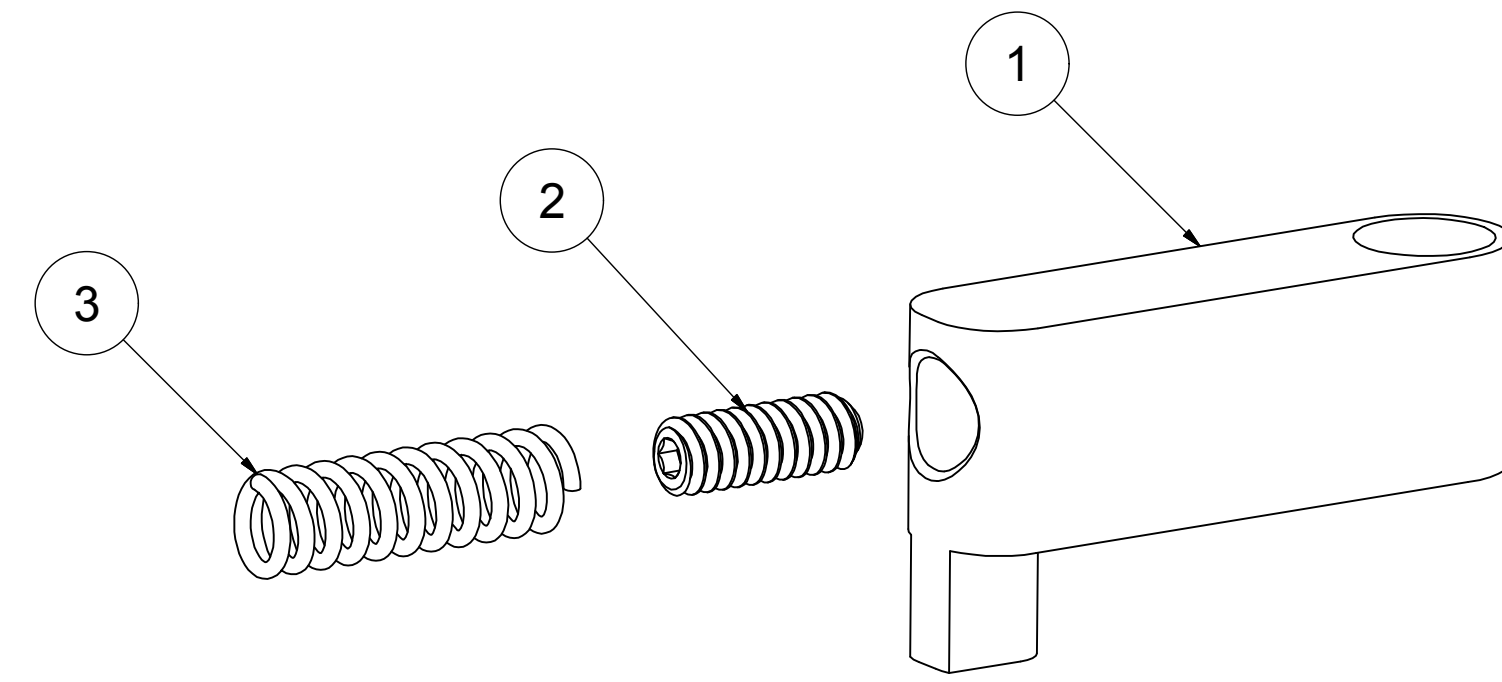
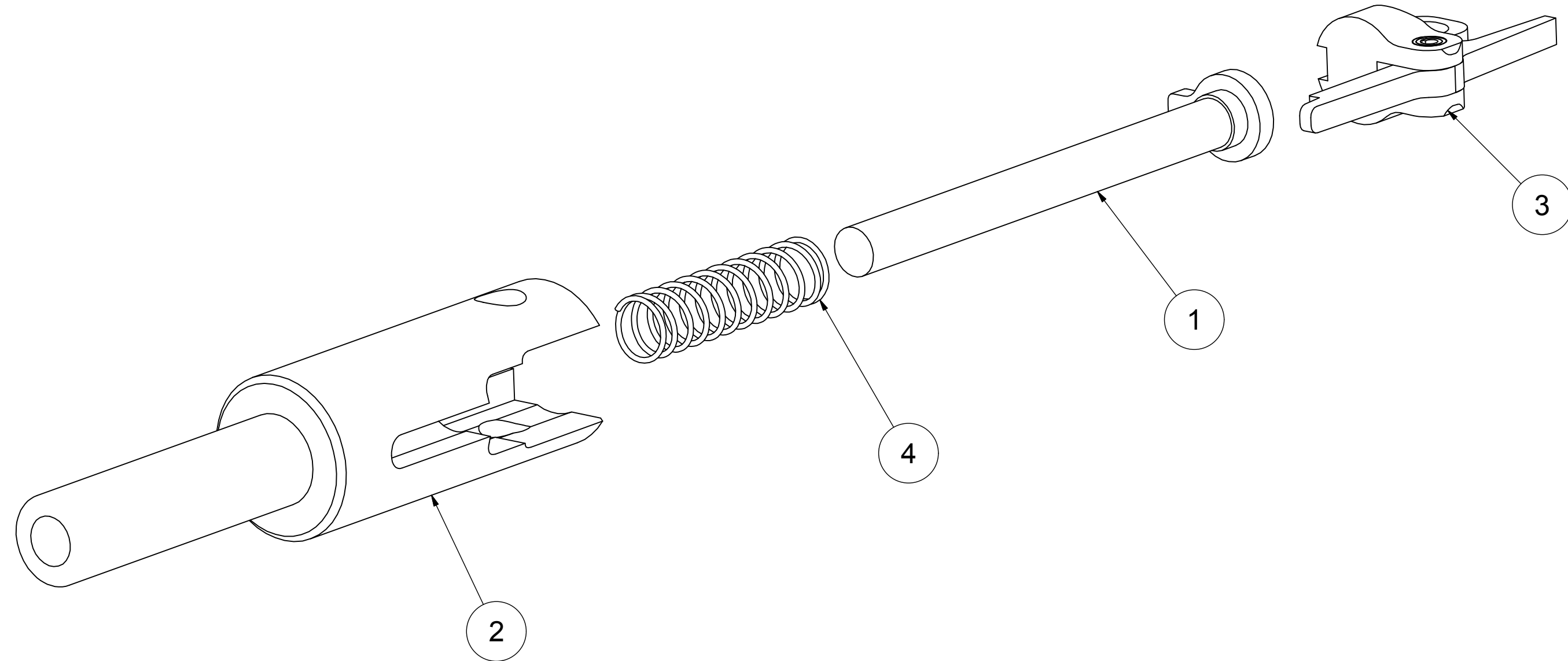

Parts List, E-100-0010-00, bolt traveler			
ITEM	QTY	PART NUMBER	DESCRIPTION
1	1	D-100-0015-00	bolt traveler
2	1	C-210-0632-06	set screw, 6-32x.38
3	1	C-035-0003-00	spring, .187x.75

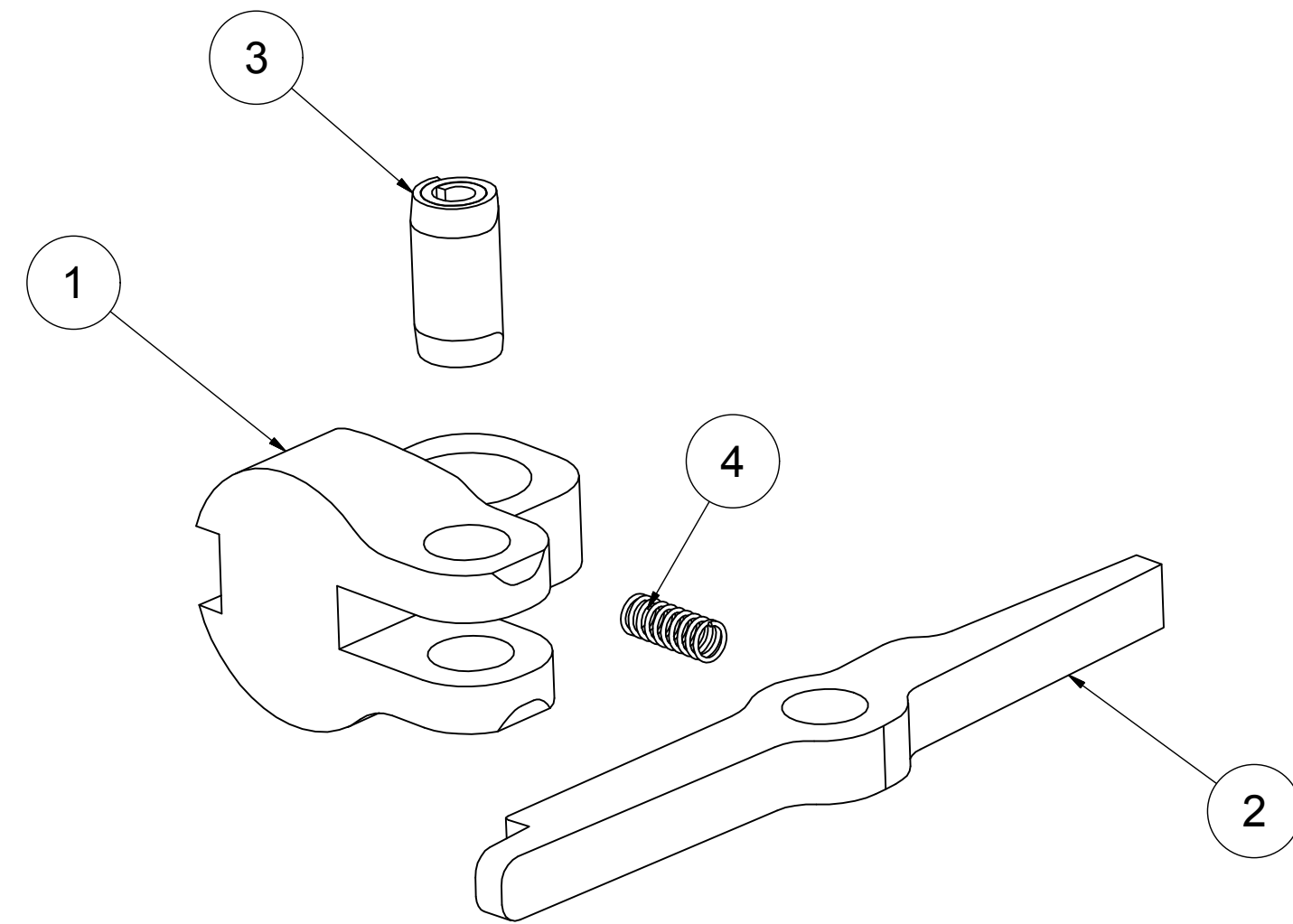

Parts List, E-100-0013-00, probe catch assy.			
ITEM	QTY	PART NUMBER	DESCRIPTION
1	1	D-100-0023-00	body, probe catch
2	1	D-100-0022-00	catch, probe
3	1	C-264-0125-04	spirol pin, .125x.25
4	1	C-035-0004-01	spring, bolt probe catch

UNLESS OTHERWISE SPECIFIED: ALL DIMENSIONS ARE IN INCHES TOLERANCES ARE: FRACTIONS ANGLES DECIMALS +/- .1/32" +/- .5 .XX=.01 XXX=.005	APPROVALS	DATE	<b>American Air Arms</b> (661) 468-7520 www.americanairarms.com		
	Tom	1/3/2018			
SURFACE FINISH 63 ✓	MECH.		TITLE Receiver, Upper Assembly, 357 LH		
	PROD.		SIZE B	PROJECT	REF: P/N E-100-0002-01
MATERIAL:	QA		SCALE NONE	FILE TYPE / NAME INVENTOR: E-100-0002-01.idw	REV A
FINISH:	CONFIG.		SHEET 2	OF 2	