

8 7 6 5 4 3 2 1

PROPRIETARY NOTICE:
 TECHNICAL DATA AND DESIGNS DISCLOSED HEREIN ARE THE
 EXCLUSIVE PROPERTY OF AMERICAN AIR ARMS AND / OR CONTAIN
 PROPRIETARY RIGHTS OF OTHERS AND ARE NOT TO BE USED FOR
 MANUFACTURE OR OTHER PURPOSE WITHOUT PRIOR WRITTEN
 AUTHORITY OF AMERICAN AIR ARMS.

REVISION HISTORY			
REV	DESCRIPTION	DATE	APPROVED
A	INITIAL RELEASE	01/04/2018	TC

Notes:
 1) All pins are inserted from the left side.
 2) Use Loctite #242.
 3) Metering screw must be removed before
 removing valve assembly.

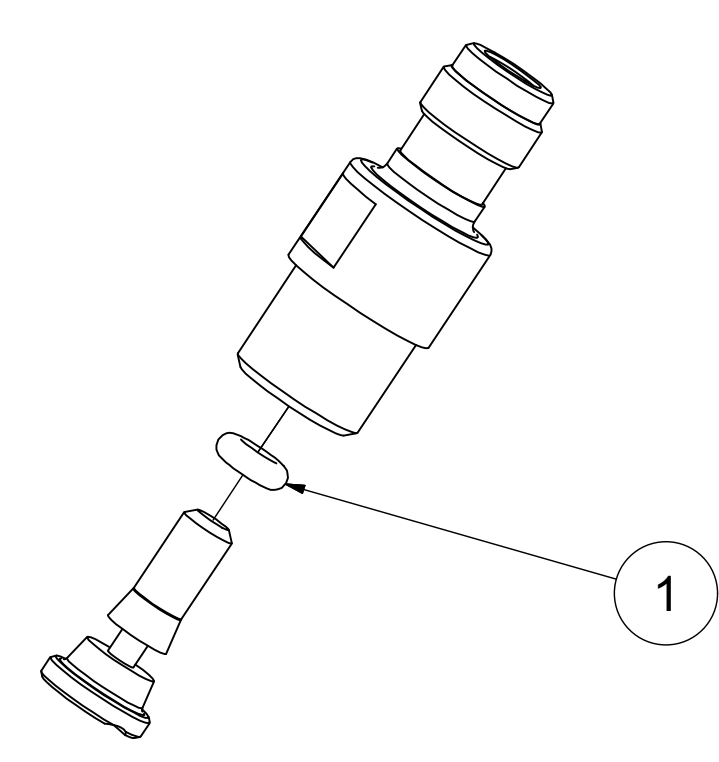
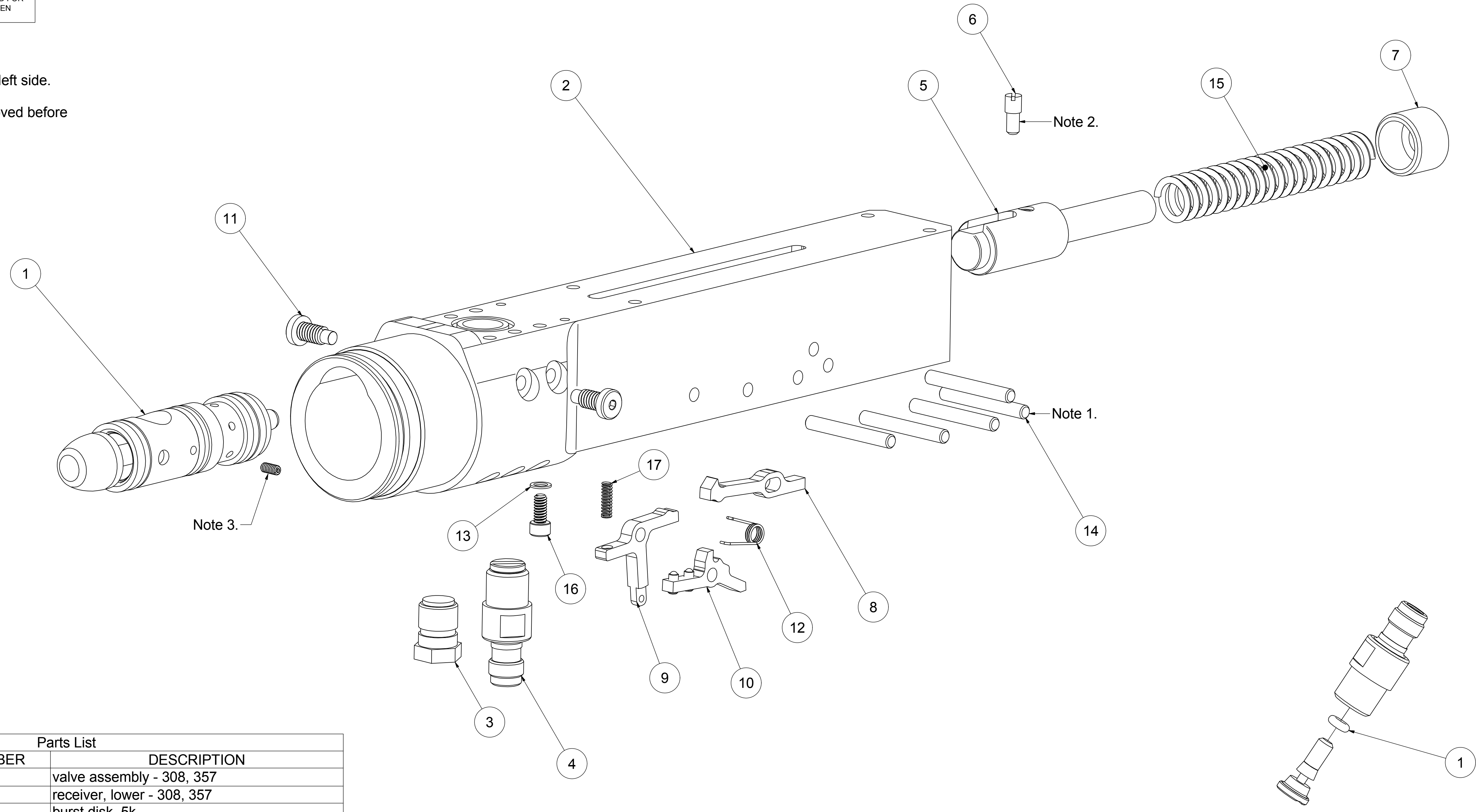

Parts List			
ITEM	QTY	PART NUMBER	DESCRIPTION
1	1	E-200-0001-00	valve assembly - 308, 357
2	1	D-100-0001-00	receiver, lower - 308, 357
3	1	C-030-0010-50	burst disk, 5k
4	1	E-100-0008-00	foster, Slayer
5	1	D-100-0005-00	hammer, 36gm
6	1	D-100-0006-00	guide pin, hammer
7	1	D-100-0007-00	adjuster, hammer spring
8	1	D-100-0008-00	sear, drop
9	1	D-100-0009-00	sear, lever
10	1	E-100-0009-00	sear, intermediate
11	2	D-100-0011-00	screw, valve retention
12	1	D-100-0012-00	torsion spring, sear
13	1	C-30-0125-16	sealing washer
14	5	C-260-0125-16	sear pin
15	1	C-350-0001-00	spring, hammer
16	3	C-200-0440-04	cap screw, 4-40X.25
17	1	C-035-0002-01	spring, lever return

Parts List			
ITEM	QTY	PART NUMBER	DESCRIPTION
1	1	C-025-0004-00	o-ring, -.04, b70

UNLESS OTHERWISE SPECIFIED:
 ALL DIMENSIONS ARE IN INCHES
 TOLERANCES ARE:
 FRACTIONS ANGLES DECIMALS
 +/- .1/32" +/- .5 .XX=.01
 .XXX=.005

SURFACE FINISH 63 ✓

APPROVALS	DATE	American Air Arms (661) 468-7520 www.americanairarms.com	
DRAWN Tom	1/3/2018	TITLE Lower Receiver, Slayer	
ELEC.		SIZE B	PROJECT
MECH.		REF: P/N	REV A
PROD.		E-100-0001-00	
QA		SCALE NONE	FILE TYPE / NAME
CONFIG.		INVENTOR: E-100-0001-00.idw	
		SHEET 1	OF 1